

MODEL V-445ST

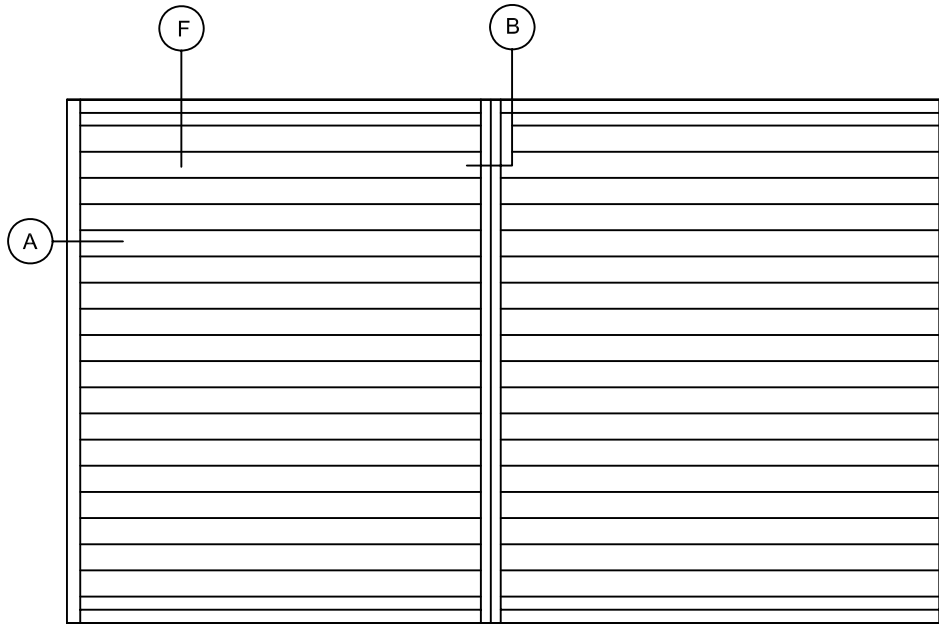

TYPE 'D' FRAME
SECTION A

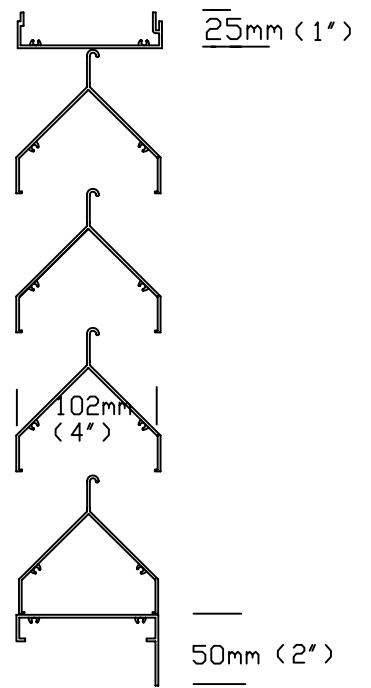

TYPE 'F' FRAME

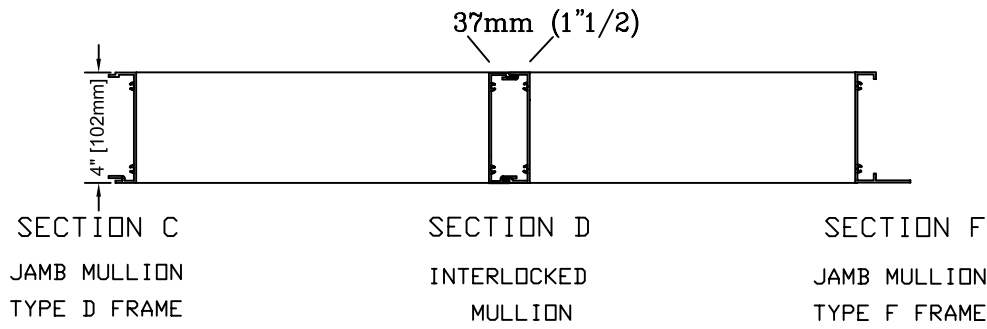

V-445ST SPECIFICATIONS

BLADES HIGH PERFORMANCE DRAINABLE ASSEMBY - S/S MECHANICAL STANDARD
WELDED OPTIONAL

FRAME DRAINCHANNEL TYPE D MATERIAL: 16 GAUGE GALV. STEEL FRAME & BLADE

MULLIONS - VISIBLE MULLION TYPE VM SCREENS - ALUM. TYPE A
1/2" X 1/2" .063 WIRE - GALVANIZED TYPE G - INSECT TYPE I
C/W FRAME 1/2" X 1/2" 19 GAUGE 18X14 ALUMINUM MESH

L#	QUANT.	OPENING SIZE		FRAME	MULL.	SECTIONS WIDE	SCREENS	LOCATION
		WIDTH	HEIGHT					
L-1								
L-2								
L-3								
L-4								
L-5								
L-6								
L-7								

McGILL LOUVERS

1734 Orangebrook Crt. (905) 420-0485 TEL.
Pickering Ontario (905) 420-4564 FAX
CANADA (888)-624-4557 TEL.
L1W 3G8 (888)-624-4558 FAX
EMAIL : engineering@the-mcgill-group.com

FINISHES

COLOUR # _____

- MILL FINISH
- 5000 SERIES AAMA -603 BAKED ENAMEL
- 10000 SERIES AAMA -605.2 KYNAR 2 COAT
- 15000 SERIES AAMA -605.2 KYNAR 3 COAT
- CLEAR ANODIZING .0004 .0007
- COLOUR ANODIZING _____

PROJECT		
ARCH/ENG.		
CONTRACTOR		
REPRESENTATIVE		
SCALE	DATE	SHEET
		OF